

MASTECH® MS6540A

**Infrared Thermometer
User Manual**

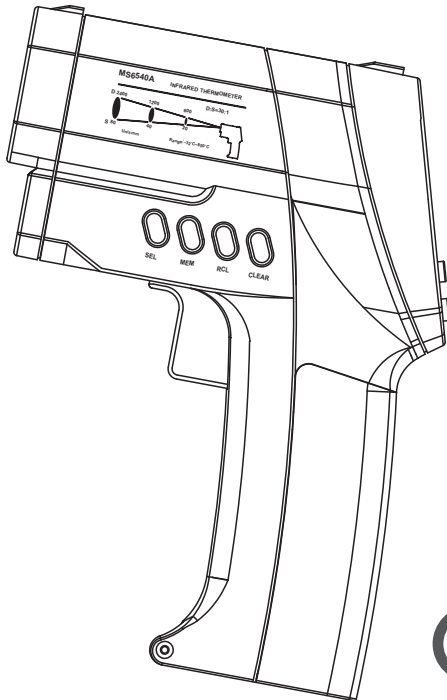

CE

CONTENTS

1. Product Overview.....	1
2. Safety Precautions.....	1
3. Appearance.....	4
4. LCD.....	4
5. Operation Instructions.....	5
5.1 Manual Measurement.....	5
5.2 Degree Celsius/ Fahrenheit Toggling.....	5
5.3 View Max/Min/ Ave/ Diff Temperature.....	5
5.4 Emissivity Settings.....	6
5.5 Temperature Limit Alarming Function.....	6

CONTENTS

5.6 Save /Recall /Delete A Record.....	7
6. Distance To Object Size Ratio (D:S).....	9
7. Emissivity.....	10
8. Maintenance.....	11
8.1 Battery Replacement:.....	11
8.2 Lens Cleaning.....	12
8.3 Housing Cleaning.....	12
9. Technical Specifications.....	12
10. Accessories.....	13

1. Product Overview

This hand-held infrared temperature sensors (hereinafter referred to as “temperature sensor”) can be used for measuring temperatures in a non-contact way, which determines the surface temperature of a test object by measuring the infrared energy radiated from the surface of the object. These are high-performance and high-quality instruments which employ micro computers for data acquisition and processing.

The instrument have such advantages as large distance coefficient, broad temperature measuring range, high precision, and fast response. Boasting multi functions including emissivity adjusting, maximum temp. reading, minimum temp. reading, average temp. reading, temp. difference and upper/lower temp limit setting, over-limit alarming, etc., the temperature sensors are nevertheless of small size and light weight, easy to operate, and very reliable. The devices can be widely used in the industries of petroleum, chemical engineering, railway, medical care, power, metallurgy, textile, plastics, metalworking, energy-saving, etc., where rapid and non-contact surface-temperature measurements are needed.

2. Safety Precautions

WARNING

- Please do not direct laser beam into the eye directly, or indirectly through reflection.
- Please check the housing of the temperature sensor before using. Never use a damaged sensor. Check for any damage or any missing plastic/rubber part.

- The battery should be replaced immediately in case the battery indicator () is shown on display.
- In case the temperature sensor does not function well, please stop using it. The protecting device of the sensor may have been damaged. If it appears to have any problem, please send the sensor for repairing.
- Never use a temperature sensor where there is explosive gas, vapor or dust nearby.
- Please do not connect the attached probe to a powered-on circuit.
- In order to avoid being burnt, please be noted that the measured temperatures for an object with high reflectivity are lower than its actual temperature.
- In case the temperature sensor is not operated in accordance with the instructions as stated in this manual, the protecting function provided for the device might not function well.

Attention

To avoid damaging the temperature sensor or the equipment to be tested, please protect them from the following hazards or improper handling:

- Static charge
- EMF (electromagnetic field) generated by an arc welder or induction heater, etc.
- Heat impact (Heat impact is caused by large or abrupt change of the ambient temperature, in which case one has to wait for 20 minutes to stabilize the sensor before using).
- Please do not place the sensor on or close to a high-temperature object.

The temperature sensor conforms with the following standards:

- EN61326-1 EMC(Electromagnetic Compatibility)
- EN61010-1
- EN60825-1 Safety specifications

Symbol and Safety Label

The symbols and safety labels used on the temperature sensor and in this manual are listed in Table 1 and Figure 1.





Symbol	Symbol
	High voltage hazard. Danger level is higher than that of "CAUTION" label!
	Danger
	Caution: Laser
	Conforms with requirements of EU and EFTA

Table 1. Symbols



Figure 1 Laser Safety Label

3. Appearance

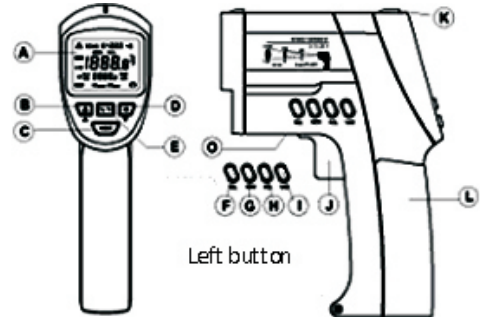

- A. LCD
- B. Laser key
- C. Mode selection key
- D. Backlight key
- E. °C/°F toggle key
- F. Function selection key
- G. Save key
- H. Recall Data key
- I. Clear data key
- J. Trigger
- K. Aiming device
- L. Battery cover

4. LCD

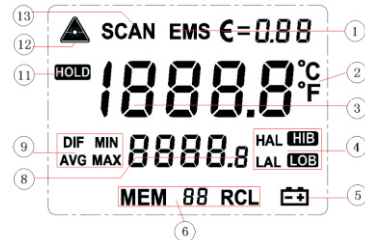

1. Emissivity display. Emissivity is adjustable when EMS symbol is on display.
2. °C/°F symbol (degree Celsius / Fahrenheit)
3. The first temperature display
4. Symbol of high-alarming and low alarming
5. Battery low symbol
6. Memory / saved data / saved-data retrieving indicator
8. The second temperature display (maximum, minimum, average, and temperature difference)
9. Symbols for the maximum, the minimum, the average, and temperature difference.
11. Hold the reading
12. Symbol for "starting" the laser aiming device
13. Measuring mode (flashing symbol indicates manual measuring, and static symbol indicates auto measuring)

5. Operation Instructions

5.1 Manual Measurement

To measure temperature, point the temperature sensor right toward the object, and then pull the trigger to start it. Please do pay attention to the optical resolution(D:S) and the observation view. The laser is used only for the aiming purpose.

5.2 Degree Celsius/ Fahrenheit Toggling

Gently touch the °C/°F key on the panel to conveniently toggle between degree Celsius and degree Fahrenheit.

5.3 View Max/Min/Ave/Diff Temperature

Gently touch the MODE key on the panel to switch the flashing symbol at the lower-left corner of the panel cyclically in the shown order.

5.4 Emissivity Settings

- 5.4.1 Emissivity is a measure of the radiation energy of the corresponding material. Most organic material and painted surfaces or oxidized surfaces have an emissivity of 0.95. The preset emissivity of the temperature sensor is 0.95. The readings might not be accurate when measuring shining metal surfaces. To correct the readings, you can use opaque photo paper or black paint to cover the test surface (< 148°C/300°F). Wait until the temperature of the photo paper or paint is the same as that of the covered surface. Then, measure the temperature of the photo paper or the surface of the paint.
- 5.4.2 Pull the trigger on the sensor and wait the sensor to be switched to the measuring mode, and then gently touch "SEL" key on the sensor twice. The emissivity symbol "EMS" will be shown on LCD, together with the value of emissivity E=1.00.
- 5.4.3 Gently touch the "▲" key on the panel to increase the emissivity value as shown on display; Press the "▼" key to decrease it.
- 5.4.4 After the above setup is complete, press "MODE" to confirm the value of emissivity.
- 5.4.5 The effective setup range for radiation: "EMS" is between 0.10 and 1.00.

5.5 Temperature Limit Alarming Function

- 5.5.1 Pull the trigger on the sensor, and gently touch "SEL" key on the left panel consecutively for three times, and then "HAL" symbol and "1000" are shown on display, and the sensor is switched to the mode for setting the upper limit alarming. Gently touch "▲" or "▼" to adjust the upper temperature limit alarming value.

- 5.5.2 After the value is set, gently touch “MEM” key on the panel to turn on/off the alarming mode. When under “alarming on” mode, “**HIB**” symbol is shown on display.
- 5.5.3 Pull the trigger on the sensor, and gently touch “SEL” key on the left panel consecutively for four times, and then “LAL” symbol and “00” are shown on display, and the sensor is switched to the mode for setting the lower limit alarming. Gently touch “▲” or “▼” to adjust the lower temperature limit alarming value.
- 5.5.4 After the value is set, gently touch “MEM” key on the panel to turn on/off the alarming mode. When under “alarming on” mode, “**LOB**” symbol is shown on display.
- 5.5.5 When the sensor detects that the surface temperature of an object is higher or lower than the preset alarming value, it will give off “doo-doo” alarming sound, in the mean time “HAL” or “LAL” symbol will flash on display.

Under the attached probe measuring mode, the upper/lower limit alarming function is deactivated.

5.6 Save /Recall /Delete A Record

- 5.6.1 The sensor can save data (up to 100 data positions). It can also save infrared radiation temperature, temperature standard (°C or °F) and emissivity.
- 5.6.2 To save the readings of an infrared measurement, you need to pull the trigger. In the mean time, gently touch “MEM” key, and “MEM” (recording) is shown at the lower left corner of LCD. The Number for the recorded position is shown at the side of “MEM”(recording) symbol.

- 5.6.3 Repeat the above steps to record again. When a record position number of “99” is shown, pressing “MEM” will not activate data recording.
- 5.6.4 To recall the saved data of an infrared measurement, you need to pull the trigger. Then, gently touch “RCL” key, and “RCL”(recall) is shown at the lower left corner of LCD; Gently touch “▲” or “▼” to select the position number of the recorded data, and in the mean time, the saved temperature values are shown on LCD.
- 5.6.5 “Record Clear” function allows you quickly clear all data records saved in the temperature sensor. This function is effective only when the sensor is under “RCL”(recall) mode. No matter how many data records are saved in the sensor, you can use this “clear” function.
Attention: Use “Record Clear” function only when all data records saved in the memory of the temperature sensor are to be deleted.
- 5.6.6 To use “Record Clear” function, you need to release the trigger under the “RCL”(recall) mode, and then press “SEL” key for 3 seconds to switch off the “RCL”(recall) mode. This indicates that data records have been cleared.

6. Distance To Object Size Ratio (D:S)

The temperature sensor has an angle of view and a range of view, as shown in the picture below.

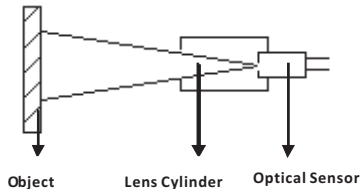

Make sure that the test object fully occupies the range of view of the temperature sensor, i.e., let the sensor “see” the test object only, without “seeing” any other object. The larger the object is, the longer the measuring distance must be; On the contrary, the smaller the object is, the shorter the distance must be. Measuring distance to size of the test object ratio (D:S ratio) is 30:1, as shown in the graph below:

In order to make sure that the temperature sensor does not receive infrared radiation from objects other than the test object, it is advisable to carry out measurements in a distance shorter than what is calculated according to D:S.

7. Emissivity

Emissivity is a measure of the radiation energy of the corresponding material. This temperature sensor allows you to adjust the emissivity of the sensor according to the type of the test surface. Please refer to Table 2.

Table 2. Surface Emissivity

Test	EMS	Test Surface	EMS
Metal		Iron	
Aluminum		Oxidized	0.5-
Oxidized	0.2-	Rusted	0.5-
Alloy A3003		Iron (Cast)	
Oxidized	0.3	Oxidized	0.6-
Roughened	0.1-	Unoxidized	0.2
Brass		Molten	0.2-0.3
Polished	0.3	Iron	
Oxidized	0.5	Dull	0.9
Copper		Lead	
Oxidized	0.4-	Rough	0.4
Elec.	0.6	Oxidized	0.2-
Haynes		Molybdenum	
Alloy	0.3-	Oxidized	0.2-
Inconel		Nickel	
Oxidized	0.7-	Oxidized	0.2-
Sandblasted	0.3-	Platinum	
Electropolish	0.95	Black	0.9

Table 2. Surface Emissivity (continued)

Test	EMS	Test Surface	EMS
Steel		Clay	0.95
Cold-Rolle	0.7-	Concrete	0.95
Ground	0.4-	Cloth	0.95
Polished	0.1	Glass	
Zinc		Plate	0.85
Oxidized	0.1	Gravel	0.95
Non-Metal		Gypsum	0.8-0.9
Asbestos	0.95	Ice	0.98
Asphaltum	0.95	Limestone	0.98
		Paper	
Basalt	0.7	(of any	0.95
Carbon		Plastic	
Non-oxidiz	0.8-	Opaque	0.95
Graphite	0.7-	Earth	0.9-
Carborund	0.9	Water	0.93
Ceramic	0.95	Wood(natur	0.9-

8. Maintenance

8.1 Battery Replacement:

When the battery is exhausted, the battery indicator  is turned on, which warns you that it is time to replace the battery. Hold the middle part of the battery lid with your fingers, and pull the lid downward, and then replace the 9V battery with a new one.

8.2 Lens Cleaning

Firstly, use clean compressed air to blow off any small particles on the lens surface, and then use a damp cotton swab to carefully clean the surface. You may use a little amount of water to dampen the cotton swab.

8.3 Housing Cleaning

Use sponge or soft cloth dampened with soap and water to clean the housing.

9. Technical specifications

♦ Temperature range for infrared measurement:

Model	Temperature Range
	-32 to 850 °C (-25 to 1562 °F)

Accuracy:

- >510 °C: ±1.5% of the reading
- 50 ~510 °C: ±1.5% of the reading +1°C
- 15 ~ 50 °C: ±1.5% of the reading + 2°C
- 32 ~15 °C: ±3 °C
- repeat error: < ±0.5 % of the reading, or ± 0.5 °C

- ◆ Optical Resolution (D:S) (30:1)
- ◆ Co-axial laser aiming mode
- ◆ Temperature Resolution: 0.1 °C or 0.1 °F
- ◆ LCD with double temperature display and 4 bits
- ◆ MAX(highest), MIN(lowest), DIF(difference), and AVG(average)temperature display
- ◆ Emissivity adjustable (0.10 to 1.00), preset value: 0.95
- ◆ High-temp. and low-temp. alarm., preset value:
high=100 °C low=00 °C
- ◆ Data recording (it can record up to 100 group of data)
- ◆ Response time: 500 mSec
- ◆ Laser power: Less than 1 milli watt
- ◆ Optical Response: 8 μm to 14 μm
- ◆ Reading Hold function (HOLD)
- ◆ Battery low-voltage indicator ()
- ◆ Working Voltage: 9V battery
- ◆ Ambient temperature: -10 ~ +50 °C
- ◆ Ambient Humidity: 10% t~90% RH at 30 °C
- ◆ Storage temperature: -20 to +50 °C, without battery
- ◆ Dimensions: Length 140×56×190
- ◆ Weight: 500g

10. Accessories

Standard Accessories:

Instruction Manual	1
Leather bag	1
9V battery (6F22)	1

